



FIST-GCO2

FIST generic closure organizer

FIST is a Fiber Infrastructure System Technology.

The generic closure FIST-GCO2 is the environmentally sealed enclosure for the fiber management system that provides the functions of splice and passive component integration in the external network.

The FIST-GCO2 has the following functions and features

- Single-ended design
- Base and dome are sealed with a clamp and O-ring system
- 6 or 16 round entry/exit ports for drop cables and 1 oval port for looped cable
- The UMS (universal mounting system) profiles provide the foundation for mounting combinations of SOSA2 (splice only sub-assembly) and/or SASA2 (splitter array sub-assembly) modules, which consist of a modular grooveplate and trays
- Compatible with most common cable types: e.g. loose tube, central core, ribbon fiber
- Uncut fibers can be stored as single circuits in trays and/or as cable elements in the storage space between the profiles. Storage baskets are available for mass storage of fibers of central core cable constructions.

Dimensions and capacities

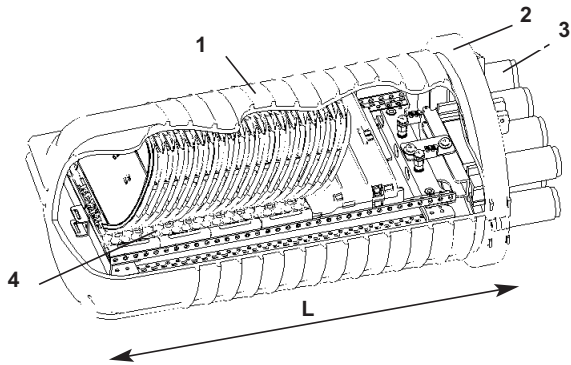

- Key**
- 1 Dome
 - 2 Clamp
 - 3 Base
 - 4 Wrap-around grooveplates

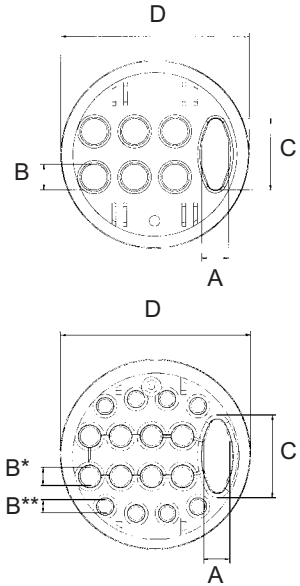

		GCO2-BC	GCO2-BD	GCO2-BE			
Dimensions in mm	L	488	566	680			
	A	30	30	30			
	B (B*/B**)	30 (20/13,5)	30 (20/13,5)	30 (20/13,5)			
	C	82	82	82			
	D	247	247	247			
	D with clamp	285	285	285			
		Fibers	Trays	Fibers	Trays	Fibers	Trays
Single circuit splicing capacity		112	56	160	80	224	112
Single element splicing capacity		336	28	480	40	672	56
R4/R8 Splicing capacity		224	28	336	42	464	58
R12 Splicing capacity		192	16	336	28	432	36

FIST-GCO2- X X X - X X

Type

- BC** 488 mm long with two 28 units UMS
- BD** 566 mm long with two 42 units UMS
- BE** 680 mm long with two 58 units UMS

Number of round ports

- 6** round ports
- 16** round ports (8 : ø 20)
(8 : ø 13,5)

Flash test point

- V** Pre-mounted flash test point in dome
- N** No pressure relief valve

Ground feed-through

- G** Pre-mounted ground feed-through
- N** No ground feed-through

For more technical options and order quantity information, please consult the products ordering guides or your local sales representative.

Tyco Electronics, TE logo and FIST are trademarks.

The information given herein, including drawings, illustrations and schematics which are intended for illustration purposes only, is believed to be reliable. However, Tyco Electronics makes no warranties as to its accuracy or completeness and disclaims any liability in connection with its use. Tyco Electronics' obligations shall only be as set forth in Tyco Electronics' Standard Terms and Conditions of Sale for this product and in no case will Tyco Electronics be liable for any incidental, indirect or consequential damages arising out of the sale, resale, use or misuse of the product. Users of Tyco Electronics products should make their own evaluation to determine the suitability of each such product for the specific application.

Tyco Electronics Raychem bvba

Diestsesteenweg 692

3010 Kessel-Lo, Belgium

Tel 32-16 351 011 (USA)1-919-557-8900

Fax 32-16 351 697 (USA)1-919-557-8498

www.tycoelectronics.com

www.telecomosp.com

TC 533/DS/6 05/09

 **Tyco Electronics**

Our commitment. Your advantage.